



JF888 MACHINE IRONING MACHINE

JF-888

professional ironing machine
for knitwear.

Designed and built with the most innovative technological solutions to facilitate the operator's task, it is equipped with **high-precision tools**: automatic template system to manage the dimensions of the garment to be ironed, easily adjustable modular lasers and automatic devices for positioning and measuring the sleeves.

The **inclined steaming work surface** guarantees a perfect position for the operator, who can easily adjust and manage the emission time and quantity of steam, thus keeping the nature of the original fabric intact.

The **JF-888** is a product with an innovative and cutting-edge design from a technological perspective, suitable for meeting even the most demanding customers' needs.

JF-888 is built to allow savings thanks to the perfect insulation achieved with the help of innovative materials. All heated parts are insulated with high-performance systems and the heat is distributed only where it is needed. The result is an evident energy saving (up to 50% compared to other machines on the market).

The main features are:

- A **heated pressing surface**, with adjustable pressure force and pressure time, in order to allow a perfect result in a very short time.
- An **automatic stacker** collects the garments at the end of the conveyor belt. Careful design and the use of an innovative sliding guide system have made it possible to obtain a **working height of 80 cm**, while maintaining the structure completely inserted within the shape of the machine. The result is an extremely flexible, lightweight, maintenance-free element with a high accumulation capacity.
- The possibility of **automating the processes**: all the machine's behavior can be configured and saved by the operator.

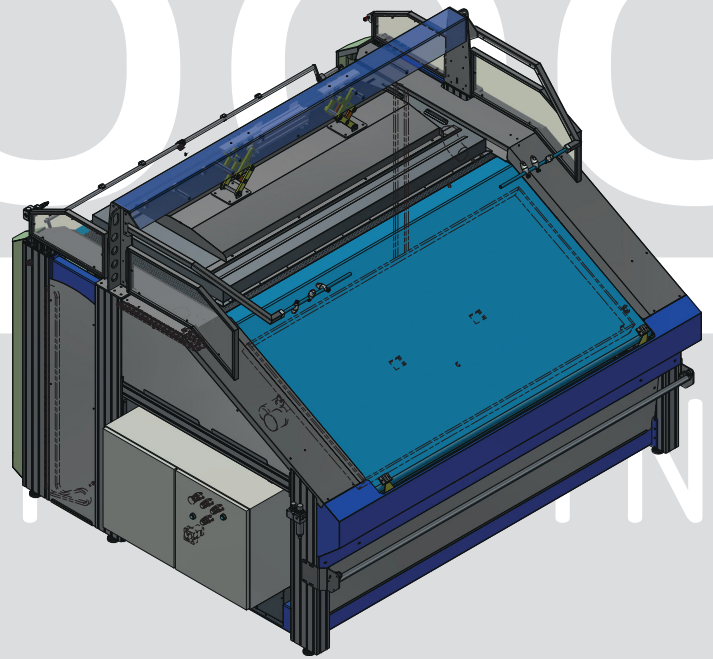
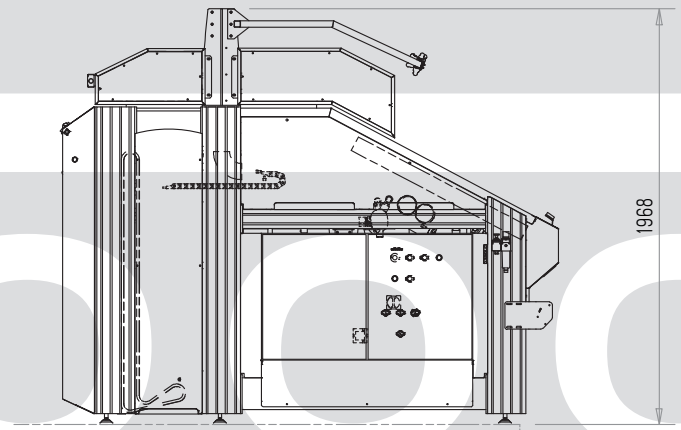
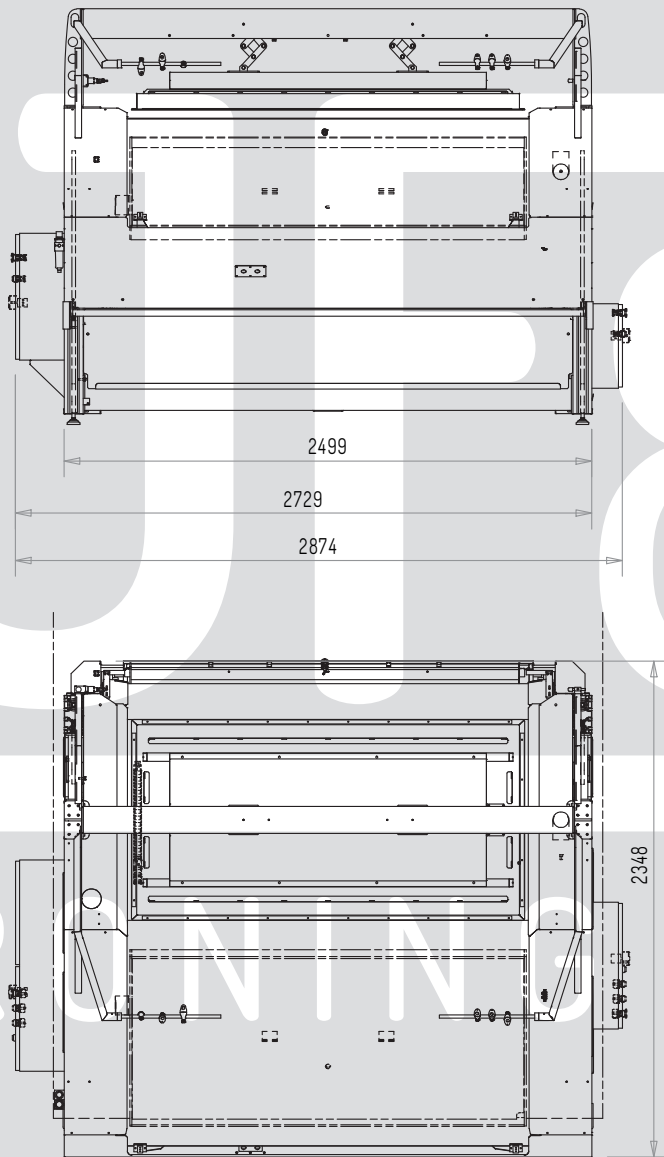

TECHNICAL FEATURES:

- Table dimensions (work surface): 1950 x 950 mm
- Adjustable speed
- Automatic adjustable shapes controlled by PLC for "sizing"
- Touch controls and management
- Modular lasers
- No lubrication required
- Possibility of connection of the machine to the feeding line from the top, leaving the surrounding space free (possibility of 360° movement around the machine with carriages)
- Stacker with extended range (+30% compared to other machines on the market)



SAVE ENERGY

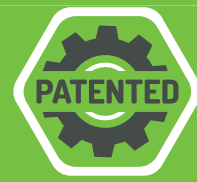

PATENTED

OPTIONAL:

- Height-adjustable operator platform
- Boiler installed on board up to 64 kW
- Remote tele-assistance service
- Aspirator with increased power
- STEAM BOOSTER: application that allows the use of all the steam produced, recovering the residual steam present in the steaming surface (up to -30% steam consumption).



MONTENERO O.M.T.P. Officina Meccanica s.a.s.

via Strozzi, 64 - 59013, Montemurlo • PRATO - Italy

PHONE +39 0574 650 737 • FAX +39 0574 650 743

info@montenero.it | www.montenero.it

